

# **WTS AB**

## **POWDER BURNERS**

**Made in SWEDEN**

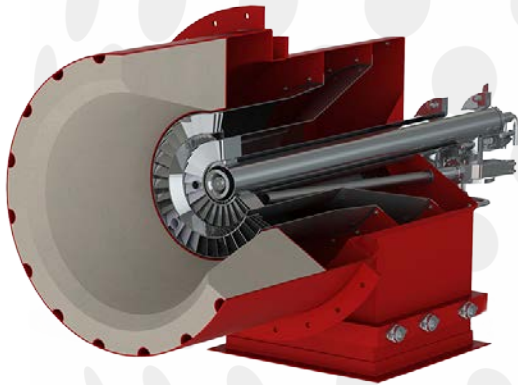

**Björn Forsberg**  
**Global Market Manager**

**[www.wtsab.com](http://www.wtsab.com)**



## **WTS AB** **POWDER BURNERS**

- **WTS AB is a Swedish multifuel burner manufacturing company specialized in wood powder combustion and we are operating world wide.**
- **We have worked with wood powder combustion and handling for more than 25 years.**
- **Our specialty is to convert oil- and coal-fired boilers to wood powder combustion for district heating, process steam, CHP and power stations.**
- **For boiler companies we also supply multi fuel burners and fuel processing equipment for new installations as a subcontractor.**
- **Our customers are found in the process industry, energy companies, pellet industry and pulp & paper companies.**
- **WTS powder combustion system works as reliable and easy as gas or oil combustion but with solid and dry renewable fuels.**





**WTS AB**  
**POWDER BURNERS**

During the last 25 years WTS has been involved in supplying wood powder burner systems worldwide.

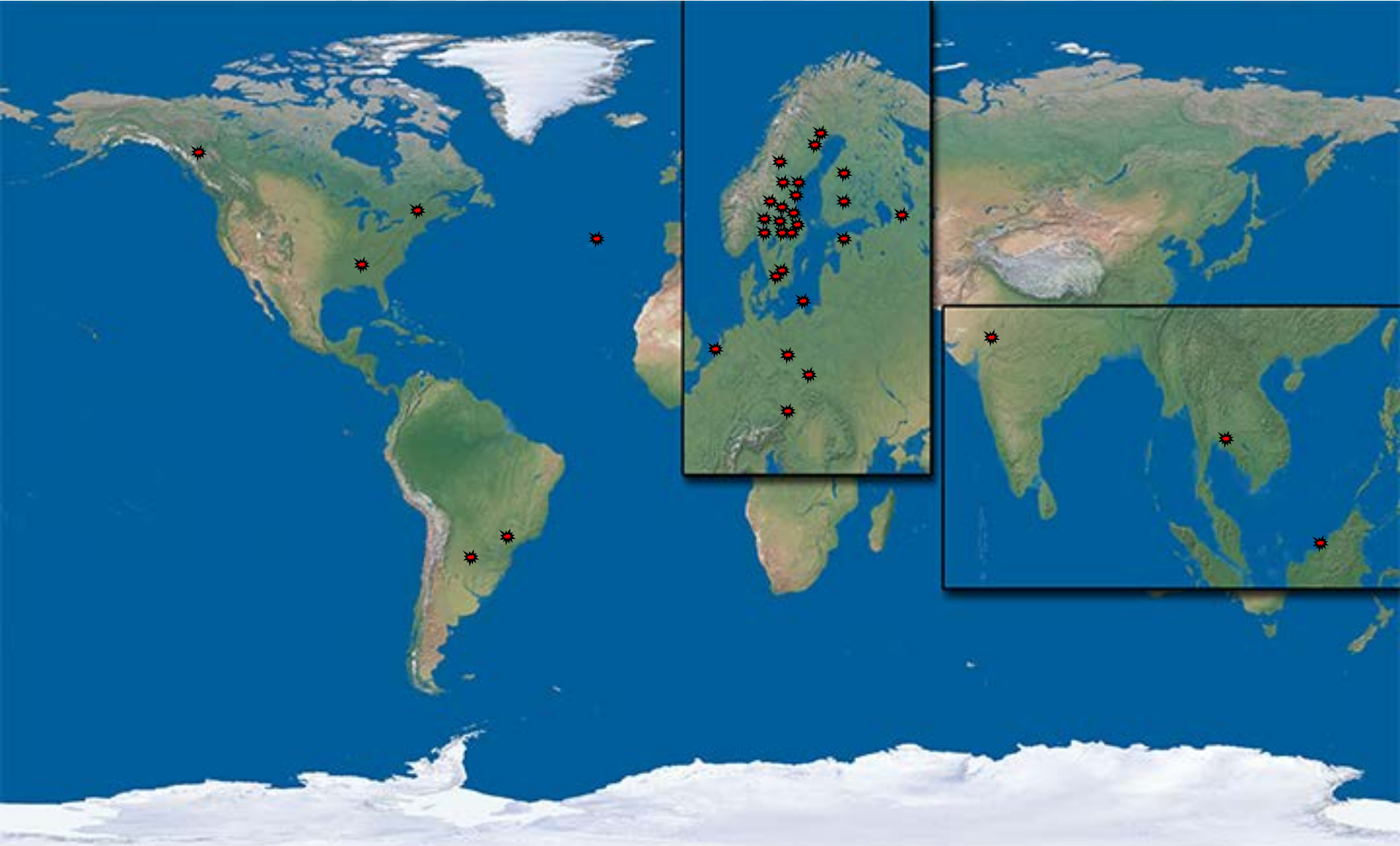



## Projects that WTS AB are working on today.

- ❖ 7,5 MWth biomass powder in Portugal. Biomass producer
- ❖ 5 MWel biomass powder in Portugal. Industrial client
- ❖ 12 MWel biomass powder in UK. Industrial client
- ❖ 2 MWel biomass powder in UK. Biomass producer
- ❖ 2,5 MWth spent wash incineration India. Industrial client
- ❖ 15 MWth biomass powder in Sweden. Biomass producer



# Burners location on boilers

Water tube boiler, top fired

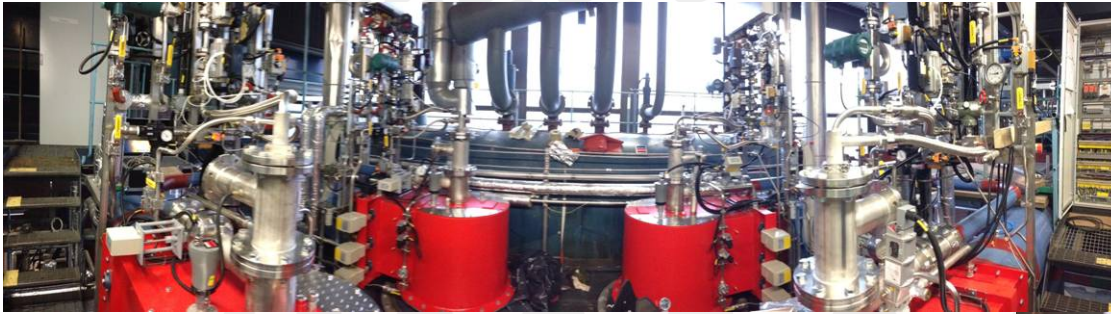

Horizontal furnace, fire-tube boilers

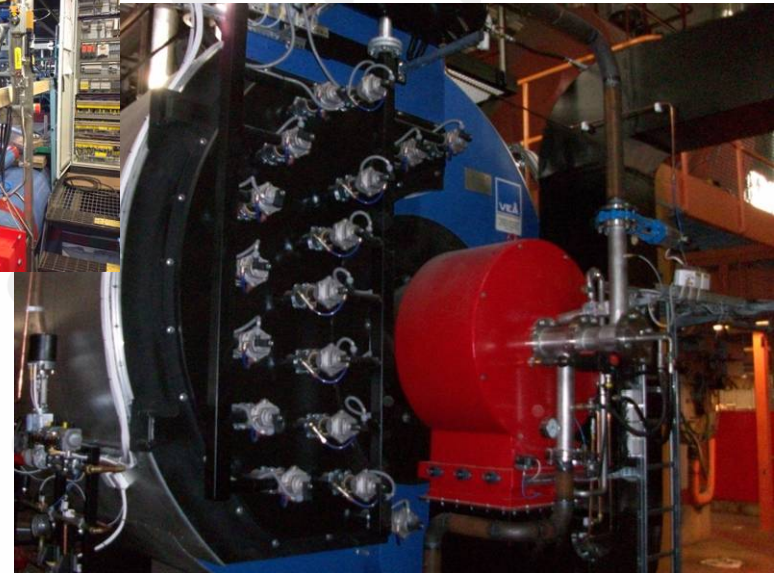

Water tube boiler CHP, tangential fired

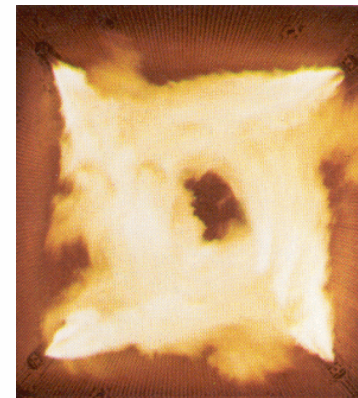
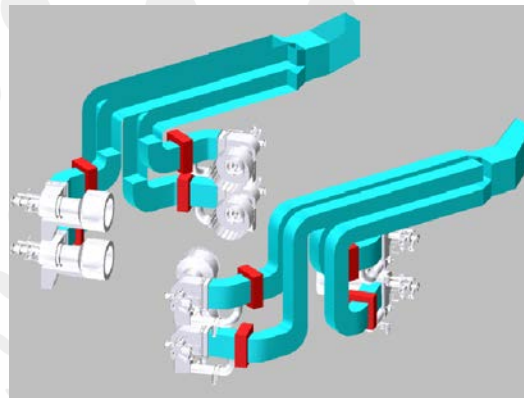



**WTS AB**  
**POWDER BURNERS**

# WTS powder/gas burner in a hot gas generator



# WTS multi fuel burners installed in boilers and dryers

Burner located over coal grate



Co-firing biomass with coal powder  
burners at CHP power plant



Vertical top fired furnace hot gas generators for biomass dryers in USA





**WTS AB**  
**POWDER BURNERS**

**WTS has also been deeply involved in Black Pellet production in USA with Zilkha and Valmet.**



## **Zilkha Black Pellets**

Advanced wood pellet that is:

- Grindable
- Low-dust
- Water-resistant
- Stored outside
- High bulk density
- Can be burned direct in existing coal power plants
- Co-fired up to 100%
- Reduced capital required

Certified sustainably harvested







**WTS AB**  
**POWDER BURNERS**

# Split view of a WTS multifuel burner for biomass powder and oil

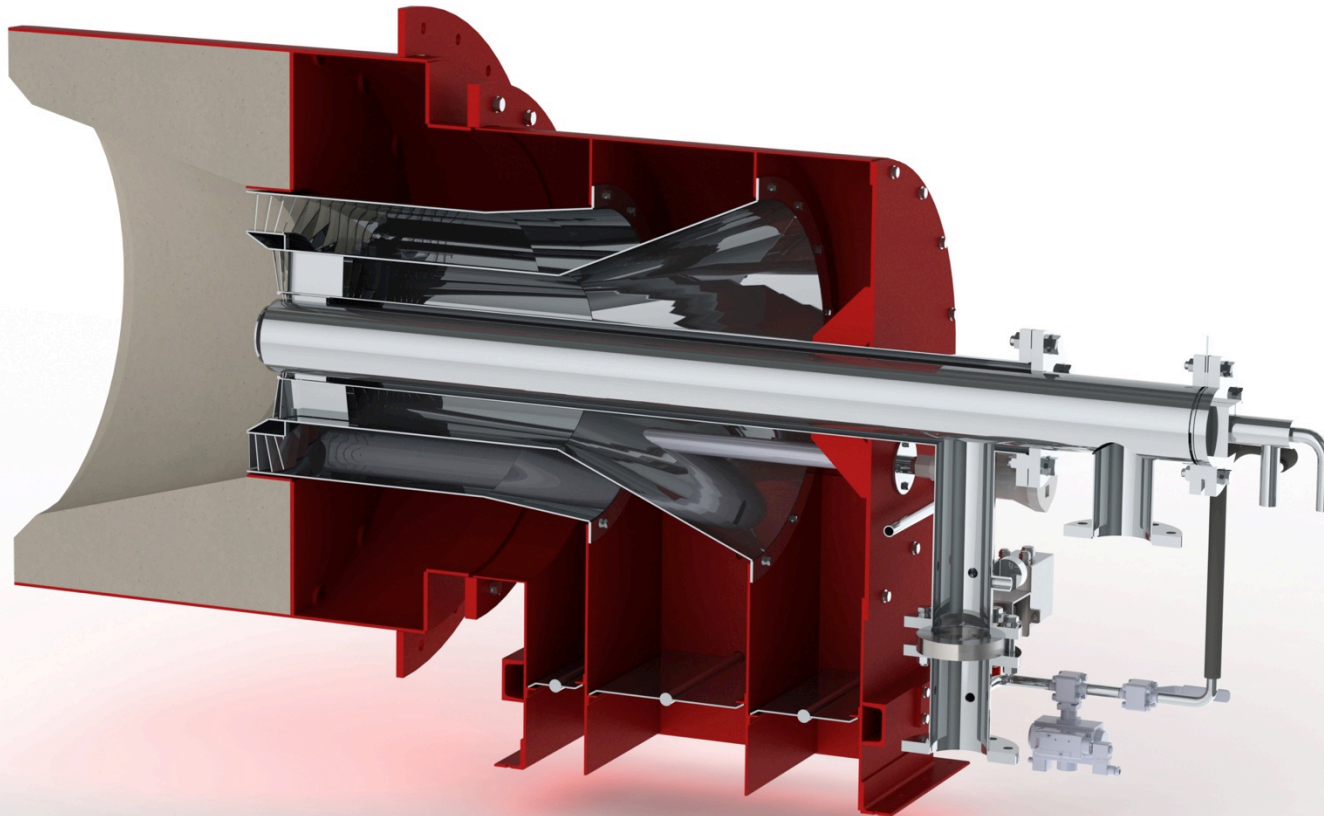

# Powder dosing system



**Dosing system for  
27MMBtu/h (8MW)  
burner**

**Dosing system for 80MMBtu/h  
(23MW) burner**



**WTS AB**  
**POWDER BURNERS**

# Principle of a small industrial boiler converted from fossil fuel to wood powder combustion

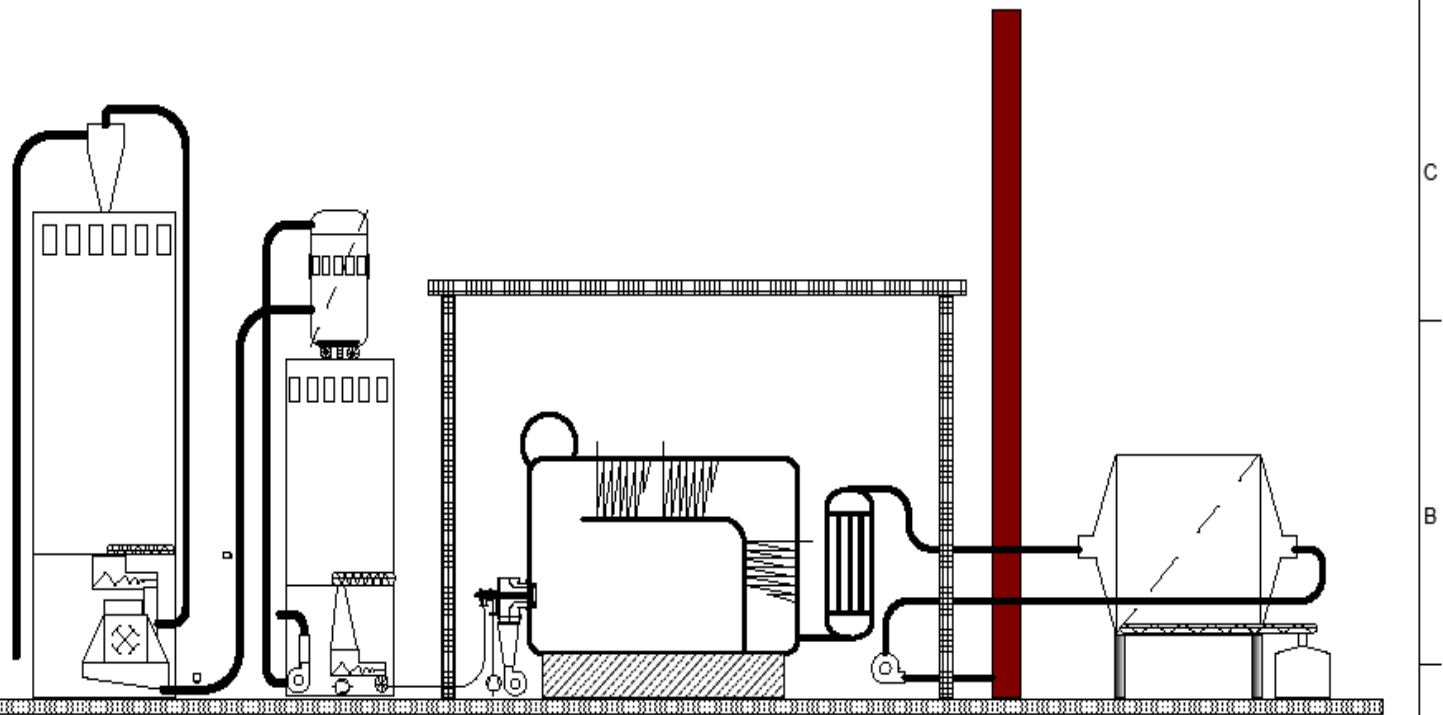

World Thermal Service AB  
Box 557  
611 10 NYKÖPING  
SWEDEN

Princip schema för pulver eldning.



**WTS AB**  
**POWDER BURNERS**

A

B

C



**WTS AB**  
**POWDER BURNERS**

## Stora Enso Paper Mill, Fors, Sweden

The boiler is a 60 MW watertube boiler for production of superheated steam

The two lower oil burners replaced by powder burners. The capacity of the new burners increased from 17 → 25 MW.

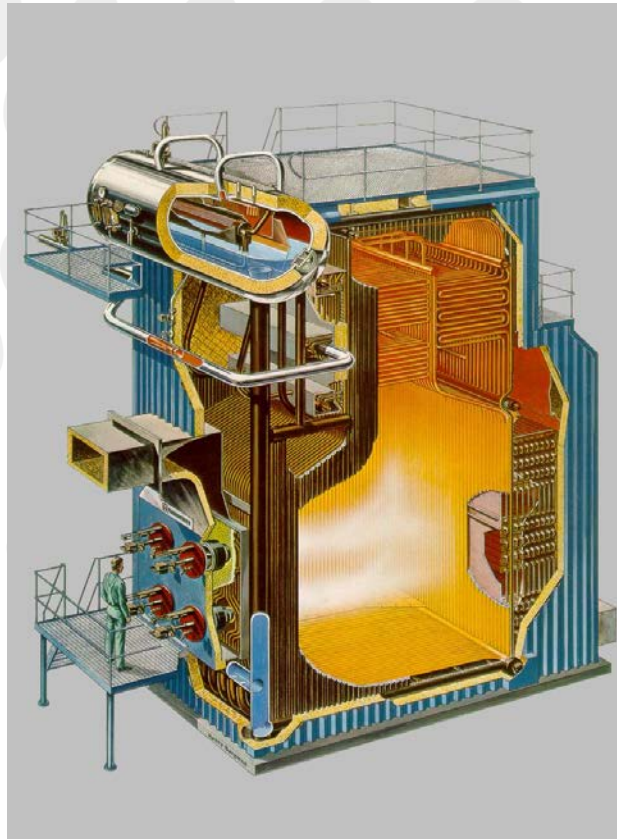



**WTS AB**  
**POWDER BURNERS**

# Project CHP Stalowa Wola, Poland. 100% conversion from coal to bio-powder



- ❖ Project in numbers:
- ❖ 8 WTS burners fuel: natural gas / biomass powder, maximum capacity 16,5 MW per burner. Total thermal load 100 MW with 6 burners in operation,
- ❖ Raw biomass silo, 5 hammer mills, powder silo, transport line from milling house to boiler house, dosing systems to burner, natural gas installation,
- ❖ Steam production for turbine: 120t/h with temperature 500° C at pressure 7,5 MPa.
- ❖ Flue gas emission: NO<sub>x</sub> and CO below contract limits.
- ❖ Biomass fuel: a wide range of biomass, wood pellets, dry micro chips and mixture of woody biomass with agro biomass.
- ❖ System is design for pellets and micro chips biomass with wide range of density,
- ❖ Total weight of delivered machinery: 240 ton
- ❖ Main contractor was RAFAKO.





**WTS AB**  
**POWDER BURNERS**

# Project CHP Stalowa Wola, Poland.

## 100% conversion from coal to bio-powder

Burner installation:

Biomass powder  
feeding system

Pneumatic transport  
Milling house → Boiler house

Milling house

ZB4  
silo

ZB3  
silo

V=200 m<sup>3</sup> Milling house building V=300 m<sup>3</sup>

4 milling  
lines

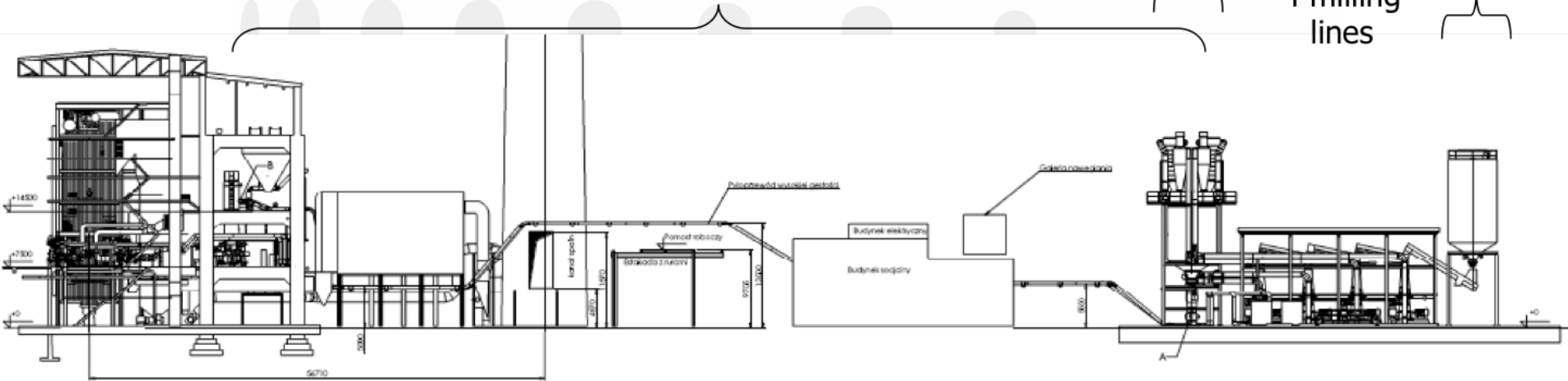



**WTS AB**  
**POWDER BURNERS**

# Project CHP Stalowa Wola, Poland. 100% conversion from coal to bio-powder

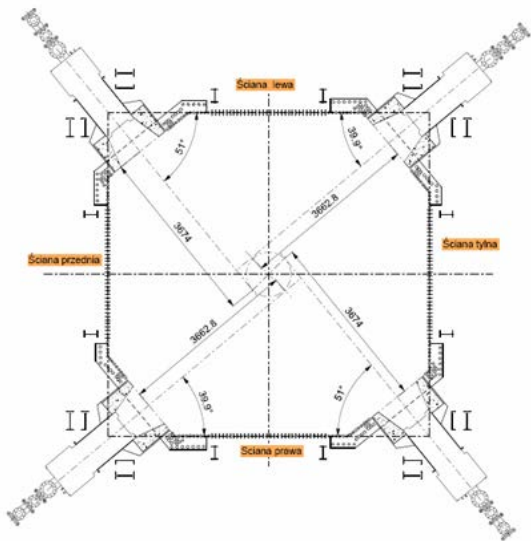
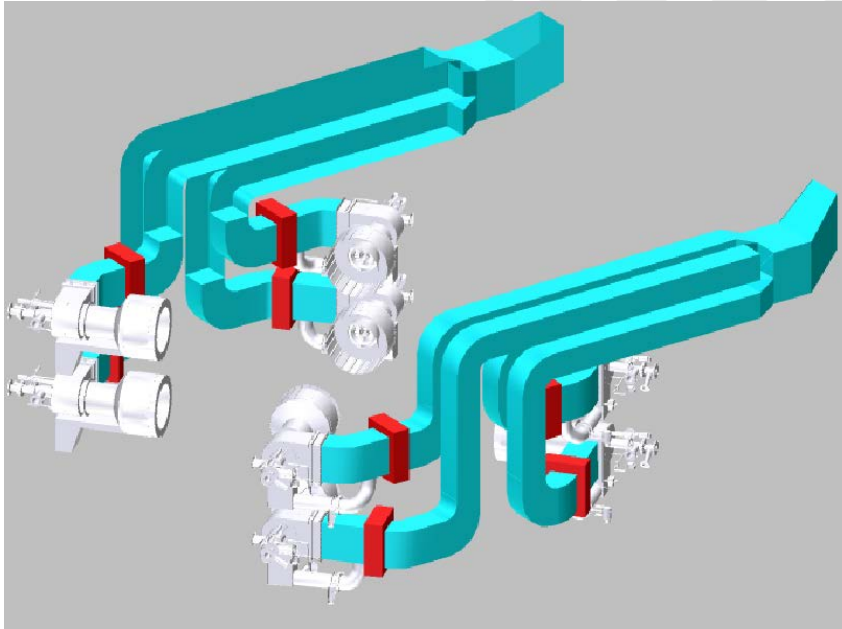

**Burner configuration  
In the corners**





**WTS AB**  
**POWDER BURNERS**

# Project CHP Stalowa Wola, Poland. 100% conversion from coal to bio-powder

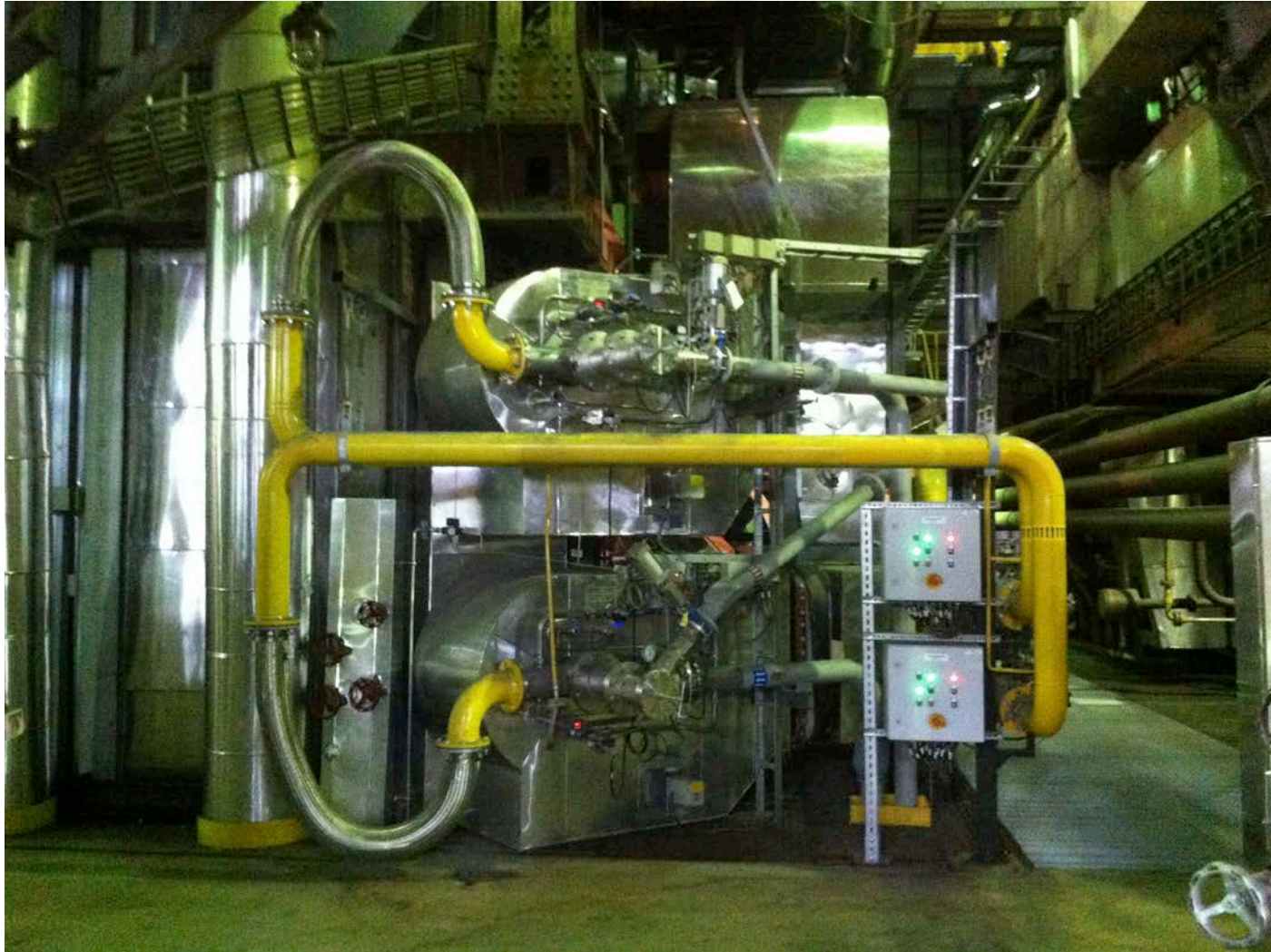

Two WTS multi fuel swirl burners in each corner and located on top of each other.

All burners can operate at 100% on biomass powder and fossil gas .









## Why Multi-fuel burners ?

- **It gives the customer an opportunity to convert existing boilers into production units with renewable fuel at a lower capital cost than building a new boiler.**
- **The original fuel (oil or gas) is still available and can always be used as back up or topping up.**
- **When installing a new combustion system in an existing boiler the customer get a dual or triple fuel installation and can choose the most preferred fuel at any time.**
- **The burners are fully automatic and fast responding to load changes.**
- **The normal fuel used in the installations is wood pellets that is milled to a fine powder. But we also have installations operating on wood briquettes and sander dust as well as dry wood chips and these are milled to a fine powder.**





**WTS AB**  
**POWDER BURNERS**

## Converting to WTS multi-fuel burner

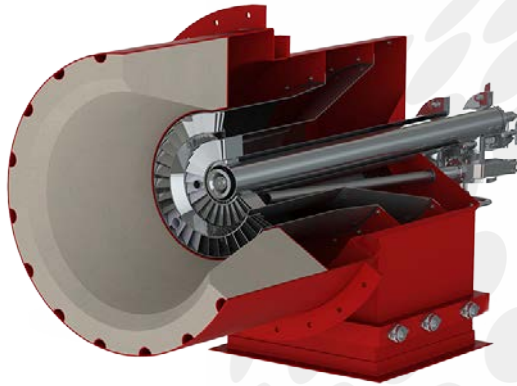

- Emissions of NO<sub>x</sub> and CO are low and no SO<sub>2</sub> emissions from pellets.
- The load response is as fast as for gas and oil burners.
- The availability is very high and maintenance costs are low.
- When operating in mixed mode, two fuels are burned at the same time in the burner, the split between powder/oil or powder/gas can be done independent from 0 –100%.
- The original fuel is always available to 100% and can be used as a backup or for topping up.
- The plant is quickly started and quickly stopped with a turndown ratio of 1:4.
- No modifications are usually needed of buildings.
- New equipment can be optimally placed on the site, since the powder transport is pneumatic and we can direct supply powder up to 150m .





**WTS AB**  
**POWDER BURNERS**

**Project Norrenergi, Solna (Stockholm) SWEDEN**



**Norrenergi District heating boiler 66 MW**

**4 x 16,5 MW wood powder and bio-oil.  
Advanced OFA installation.**





**WTS AB**  
**POWDER BURNERS**

## Project Ortviken Sundsvall, Sweden



- The city of Sundsvall had a choice to build a new biomass CHP plant for 150 M€ or to make a deal with SCA Ortviken who had available capacity in their boilers for wood powder firing. The total cost was around 45 M€
- SCA Ortviken AB selected Andritz as main contractor to convert 2 boilers from oil to biomass.  
WTS AB was selected by Andritz to deliver the powder firing technology and OFA system to minimize environmental emissions.  
WTS AB installed total 120 MW powder burner capacity .





**WTS AB**  
**POWDER BURNERS**

# Project Ortviken Sundsvall, Sweden

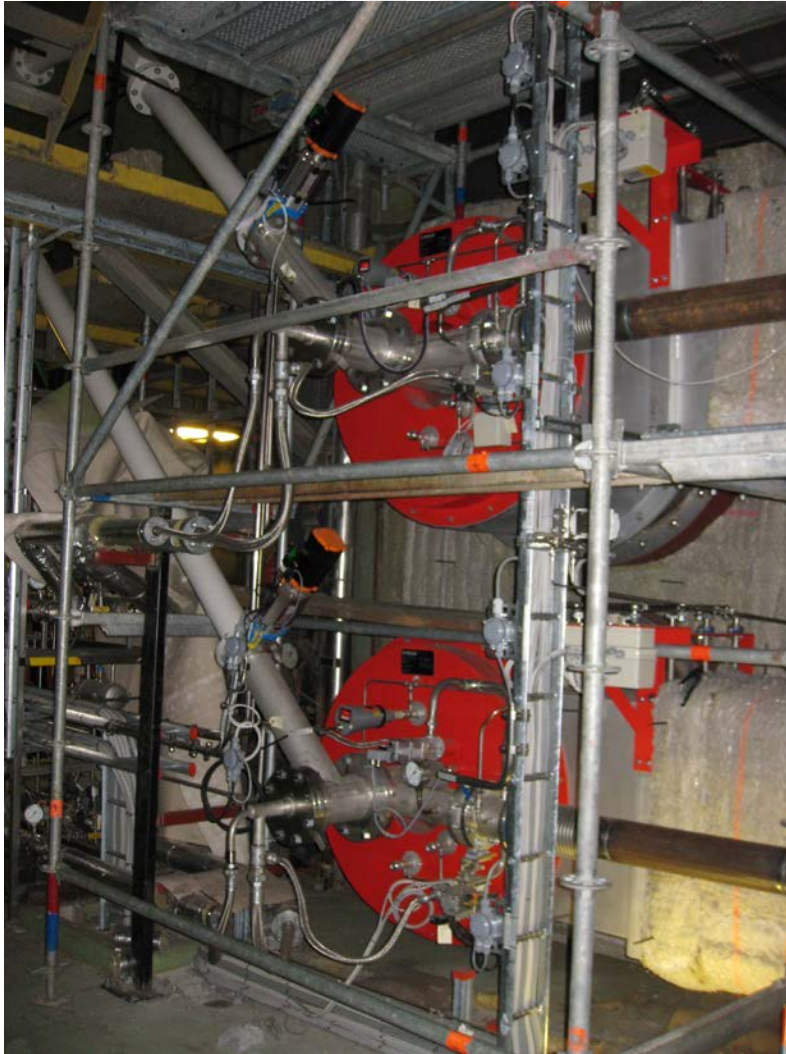

**Burners installed in 90 t/h steam boiler #2**





**WTS AB**  
**POWDER BURNERS**

# District heating plant, Tampere Finland

## Main contractor : Valmet (Metso)

- ❖ Project in numbers:
- ❖ Single wood powder burner in top fired hot water boiler,
- ❖ Firing capacity: 37MW on wood powder from pellets, 49MW on light oil,
- ❖ Peak load district heating plant.
- ❖ Output water temperature: 130°C,
- ❖ WTS AB delivery starts from feeding of mills.





**WTS AB**  
**POWDER BURNERS**

# District heating plant, Tampere Finland

## Main contractor : Valmet (Metso)

- ❖ Output 37 MW with pellets and with light oil 49 MW
- ❖ Pellet silos 2x500 m<sup>3</sup>
- ❖ Pellets are milled to dust in hammer mills.
- ❖ Dust conveyed via filter unit to dust silo V=50 m<sup>3</sup>
- ❖ Modulating operation
- ❖ Turn down ratio 1:4
- ❖ Efficiency over 92 %
- ❖ Electrostatic precipitator for flue gas cleaning
- ❖ metsoDNA automation system

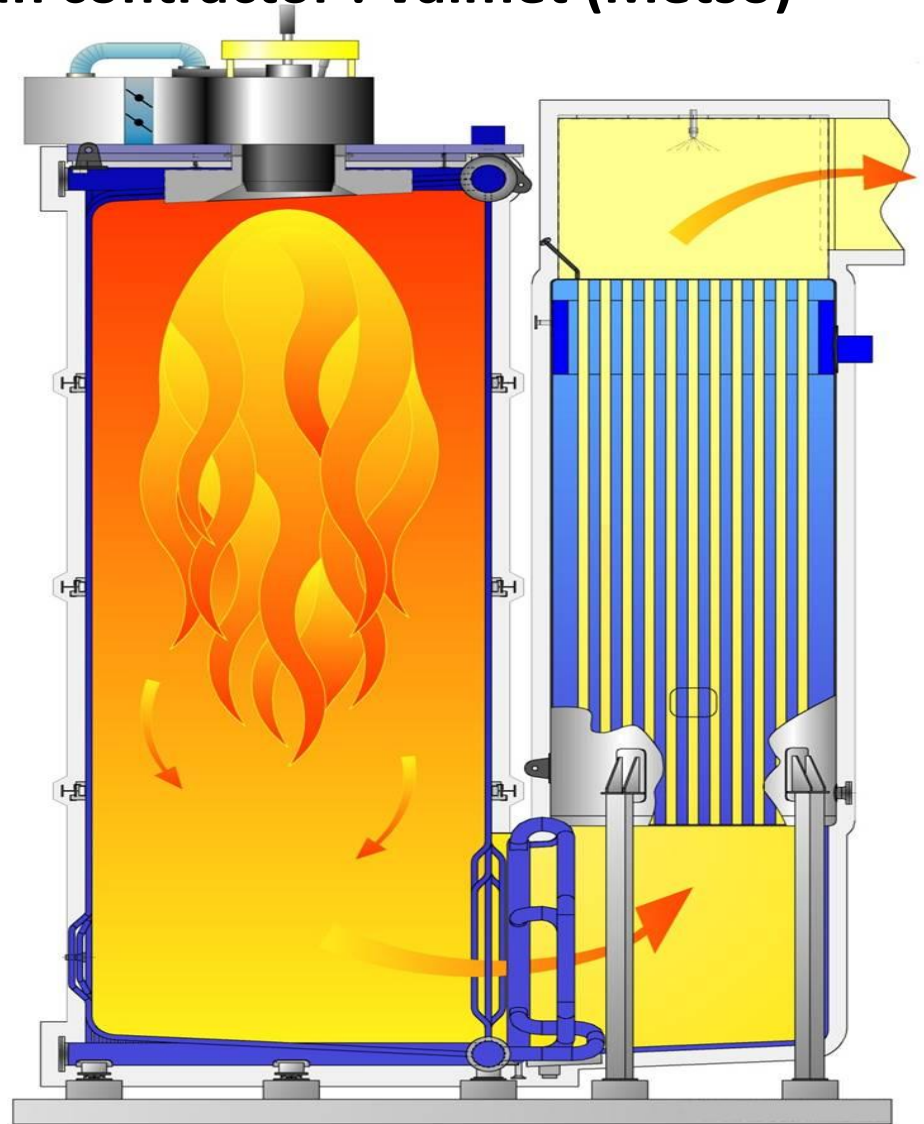





**WTS AB**  
**POWDER BURNERS**

## Project Hyvinkä, Finland

District heating plant turn-key delivery from KPA  
Unicon with WTS AB wood powder burner system.  
11 MW firing capacity.

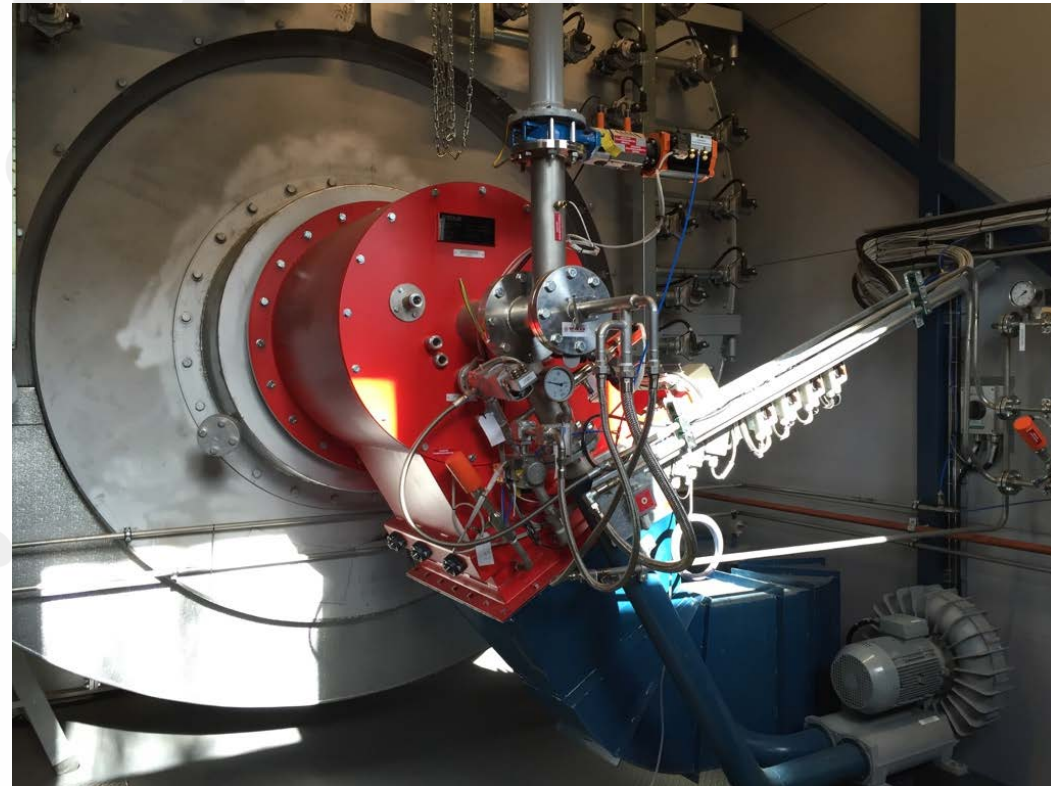

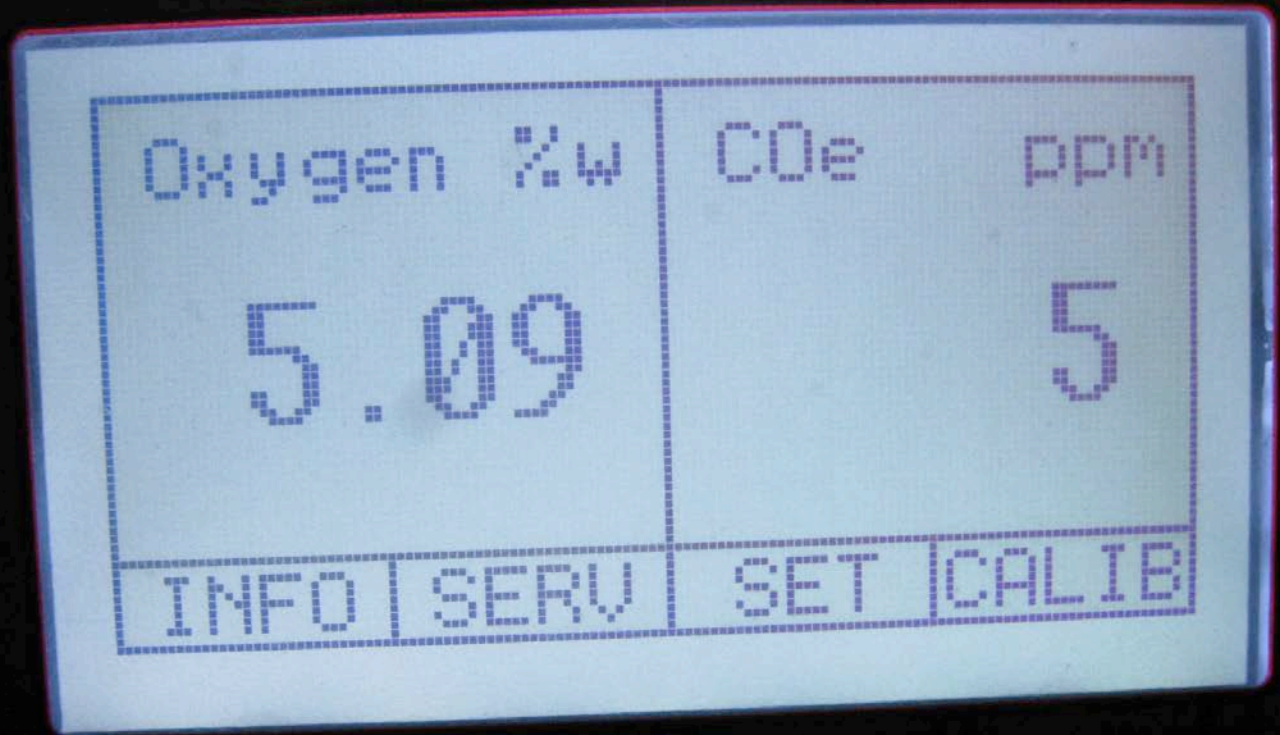



**WTS AB**  
**POWDER BURNERS**

See our website: [www.wtsab.com](http://www.wtsab.com)  
For more information.

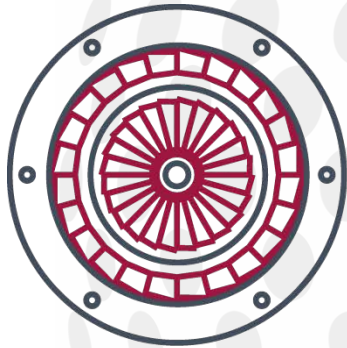

**WTS AB**  
**POWDER BURNERS**

Blommenhovsvägen 26  
SE-611 39 NYKÖPING, SWEDEN  
Phone +46 730 28 49 12

[bjorn.forsberg@wtsab.com](mailto:bjorn.forsberg@wtsab.com)

